

VLLR-3

3 Metre Vertical Long Length Rod

The VLLR-3 is designed to produce three metre long lengths of cast nylon rod.



- Pressurised casting system
- Oil circulating temperature controllers
- 4 independent process stations as standard
- Full range of interchangeable tooling

SPECIFICATION

Rod Length (F/S):	3000mm
Rod Outside Diameter (F/S):	45 to 100mm
Height (raised):	4970mm
Length (raised):	4745mm
Length (lowered):	6706mm
Width (4 tool platform):	5380mm
Weight:	2000kg
Max. Power Consumption:	6.6kW (per tool)

(F/S) Finished Size

Power supply is available in a range of industry standards to accommodate local services.

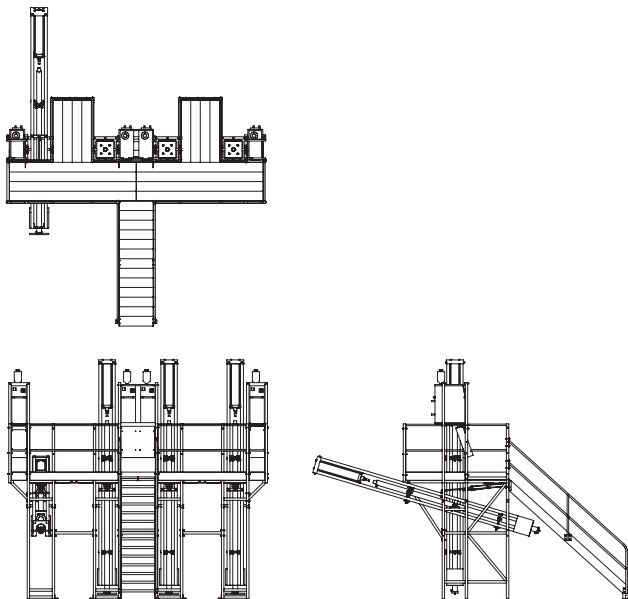

The VLLR-3 is designed to produce 3 metre long cast nylon rod. The appropriate tool is fitted into the structure and heated by means of an oil heating/circulation unit, with the monomer melt being introduced when the tool temperature is correct for the required product.

The steel box frame structure carries the rod tool and holds it rigid during the process cycle. The frame is fitted to a support stool via two bearings and can be rotated by means of a pneumatic cylinder into the filling and demoulding positions. Counterbalance weights are fitted to aid rotation of the angle frame structure about the pivot axis.

Heat for the process is provided by an oil heating/circulation unit. Oil is pumped through the tool jacket and returned to the unit for recirculation and reheating. All tools and pipework are thermally insulated to ensure efficient heating with the oil temperature being controlled electronically.

Pressure, during the production cycle, is applied by a pneumatic cylinder controlled through a manually operated valve. The amount of pressure can be regulated to suit each tool/rod size via the pneumatic pressure regulator. High temperature seals fitted to the tool piston ensure complete leak free operation throughout the cycle.

The VLLR-3 has been designed to require only minimal periodic maintenance, resulting in high production efficiency and reliability. Fault tracing is greatly simplified by the use of electronic control and monitoring equipment.

Each tool consists of an inner stainless steel tube contained within a stainless steel jacket tube. At the bottom of the assembly is a closure cap assembly through which the product is extracted. The top of the inner tube is open to allow pouring of the melt and to accommodate the tool piston. Oil inlet and outlet sockets are fitted to the jacket tube for heating purposes along with two support rings which locate into the angle frame structure. The whole assembly is fully welded and pressure tested.

Global EPP reserves the right to alter specifications without prior notice.



Global EPP